

INSTRUCTIONS FOR CHAIN LINK INSTALLATION

This guide explains how to correctly install our chain link fencing and post system. The guide provides details of which post type you will need for your fence run, how to put the posts together, and how to correctly install your posts and attach the chain link fencing.

The key point to remember with chain link fencing is that in order to achieve a rigid, strong fence your posts and struts must be concreted in, line wire needs to be tensioned along the fence line, and the chain link must be pulled tight and secured correctly to the posts and line wire. If you follow the below guidance, then anybody should be able to install our chain link post and fencing system.



Section 1: What posts do I need?

To install a strong chain link fence, and to ensure that the fencing does not sag, the chain link must be pulled as tight as possible. To retain sufficient tension in the fencing, it is important to ensure that the fence line of each run of your fencing is as straight as possible. We have set out below the types of post you will need for some of the common shapes of fencing:

- a.) **Straight run:** To install a straight run of fencing you will need two end posts (one at the start of the run and one at the end of the run), and an intermediate post every 3 metres. For longer runs of chain link you may wish to insert a straining post (a straining post is used when the weight of the chain link cannot be stretched over the full distance, for our standard weight chain link this is 50 metres, for our heavy duty chain link and our 2400mm (8ft) high chain link this is 25 meters).
- b.) **L-shaped fence:** To install an L-shaped run of fencing you will need two end posts (one at the start of the “L” and one at the end of the “L”), a corner post for the 90 degree change in direction, and an intermediate post every 3 metres;
- c.) **Inserting a gate:** To insert a gate in a run of chain link fencing, you will need two additional end posts (one must be positioned on either side of the gate posts). Essentially you are stopping the run of fencing with an end post,

inserting the gate, and then starting a new run of chain link on the other side of the gate;

- d.) **Enclosures:** To install a square or rectangular fully enclosed area you will need 4 corner posts with an intermediate post every 3 metres. Please note that you will also need two end posts to create an entrance to the area (see “Inserting a gate” above);
- e.) **Dog legs and curved fence lines:** To ensure that you have a rigid fence, chain link fencing must be tensioned properly. If there isn't enough tension in the fencing then it will sag and possibly snag. For best results in tensioning the fencing, the fence line should be kept as straight as possible.

If you have a curve or dog leg in your fence line then it may be necessary to stop the fencing with an end post, and restart it at a slightly different direction (you can restart the fencing by inserting another end post). For severe curves in the fence line, it may be necessary to erect the chain link in several small sections to account for the change in direction;

- f.) **Gradients:** Where you are installing the fencing on a gradient, the change in height can make it difficult to retain the tension in the fencing. In order to compensate for this change in height, you can tweak the installation process. The key is to ensure that the bottom edge of the chain link fence runs parallel with the ground.

The first step is to concrete in your posts and tension the line wire in the usual way (this process is explained in the below sections of this guide).

Once your posts are concreted in, you should begin with the end post at the top of the slope. Keeping the chain link rolled up, take the top corner of the chain link and clip it onto the top run of line wire (using your hog ring plier). Make sure that you use a few hog rings to ensure that the chain link stays in place.

The direction of the chain link needs to remain parallel to the ground. In order to achieve this, you will need to ensure that the bottom edge of the chain link runs in line with the bottom run of tensioned line wire (i.e. so that the roll of chain link is pointing down the slope). This will result in the bottom left corner of the chain link overhanging the upright post. This overhang will be a triangular shape on the far side of the end post.

Once you have found the correct angle for the chain link, you will need to insert (weave) the stretcher bar through each hole in the chain link at the point where the chain link is in contact with the upright post i.e. the stretcher bar should remain parallel to the end post, so you will be inserting it on the bias. You should then bolt the stretcher bar to the brackets on your end post (this will secure the fencing to the end post, leaving the excess triangle of

chain link on the other side of the post).

You can now cut off this excess of chain link (the triangle) using wire cutters. To neaten up any raw edges, you should twist them around the stretcher bar. You can continue to fix the roll of chain link to the line wire as described in this guide below. Finally, repeat this process at the other end of your run of fencing.

Section 2: How to assemble my posts

There are a number of types of post which can be used to achieve the shape of fencing you require (end post / corner post / straining post). All of these post types include an upright post, also known as an intermediate post (this is the long cylindrical post with a spine running down its length). End posts, corner posts, and straining posts also use struts to provide extra support to the upright post.

PLEASE NOTE that we supply the same length upright post for 900mm high fencing as we do for 1200mm high fencing i.e. a 1.8m long post. Therefore, for 900mm high fencing you can either bury 900mm of the post into the ground, or trim 300mm off the post length with an angle grinder.

Set out below are the fittings with each type of fence post:

A. End Posts

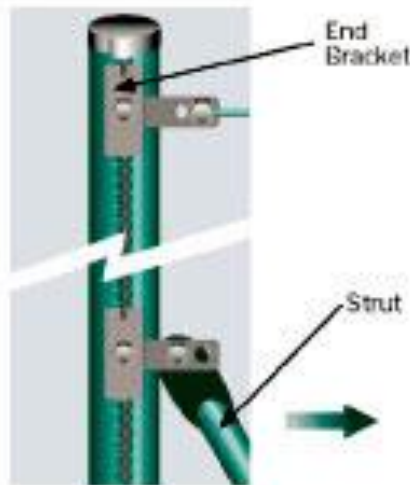

In addition to your upright post, an end post contains the following fittings:

For **900mm (3ft)** high fencing:

- 1 x strut (thinner cylindrical post with drilled hole at the end)
- 3 x end bracket (see figure 1 in “**Section 5: Fence Fittings**” below)
- 1 x stretcher bar (thin silver metal bar with drilled holes)
- 2 x winder (rotating barrel for tensioning line wire)

For **1200mm (4ft)** and **1800mm (6ft)** high fencing:

- 1 x strut (thinner cylindrical post with drilled hole at the end)
- 4 x end bracket (see figure 1 in “**Section 5: Fence Fittings**” below)
- 1 x stretcher bar (thin silver metal bar with drilled holes)
- 3 x winder (rotating barrel for tensioning line wire)

For **2400mm (8ft)** high fencing:

- 1 x strut (thinner cylindrical post with drilled hole at the end)
- 5 x end bracket (see figure 1 in “**Section 5: Fence Fittings**” below)
- 1 x stretcher bar (thin silver metal bar with drilled holes)
- 4 x winder (rotating barrel for tensioning line wire)

In order to concrete your posts into the ground, you will need to dig holes approximately 200mm x 200mm square in the appropriate positions along the fence lines. The holes need to be deep enough to bury the part of the post which will not be above ground.

To ensure that you position your post correctly, you should place an intermediate post every 3 metres along each section of fencing.

The key point to remember when you concrete in the posts is that the spines on the posts must all be in the correct position. For most runs of fencing, the spine of the post must be at a 90 degree angle to the direction of the fencing (the exception to this rule is for corner posts, see below section on corner posts for details).

This is because the brackets that fit onto the spine of the post must point in the direction of the fence (see above diagram).

How to attach your strut to the post

The strut on your end post will need to be concreted into the ground at the same time as the upright post. In order to attach the strut, you need to fix one of the end brackets to the upright post by slotting it into the holes on the spine of the post.

This bracket should be positioned in the top half of the post, approximately three quarters of the way up the post. The strut should then be bolted to this bracket (it should be at an angle of approximately 40 degrees to the post). The bottom of the strut should be concreted into the ground.

Attaching the other fittings

For **1800mm (6ft)** and **1200mm (4ft)** high fencing you will need three runs of line wire along the fence line.

Therefore, an end bracket will be required towards the top, middle, and bottom of the end post. Attach the end brackets to the upright post by slotting them into the holes on the spine of the post, and fitting the bolt through the bracket.

For **2400mm (8ft)** high fencing you will need four runs of line wire along the fence line.

Therefore, an end bracket will be required at four evenly spaced intervals on the post (including one at the top and bottom of the post). Attach the end brackets to the upright post by slotting them into the holes on the spine of the post.

For **900mm (3ft)** high fencing you will only require two runs of line wire. Therefore, you need to position an end bracket at the top and bottom of the post, and one bracket for the strut.

PLEASE NOTE: You will notice that the brackets have two holes on the bracket arm. A winder should be bolted onto the outer hole. The inner hole will be used to bolt on the stretcher bar when you come to attach the chain link to the posts (see section 4 below). Therefore, when you position the brackets onto the post, you need to ensure that the brackets are spaced so that they line up with the holes drilled into the stretcher bar (the stretcher bar does not need to be bolted to the strut bracket).

B. Corner Posts

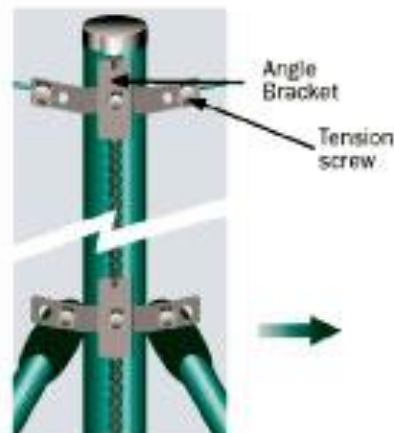

In addition to your upright post, a corner post contains the following fittings:

For **900mm (3ft)** high fencing:

- 2 x strut (thinner cylindrical post with drilled hole at the end)
- 3 x corner bracket (see figure 2 in "**Section 5: Fence Fittings**" below)
- 2 x stretcher bar (thin silver metal bar with drilled holes)
- 4 x winder (rotating barrel for tensioning line wire)

For **1200mm (4ft)** and **1800mm (6ft)** high fencing:

- 2 x strut (thinner cylindrical post with drilled hole at the end)
- 4 x corner bracket (see figure 2 in "**Section 5: Fence Fittings**" below)
- 2 x stretcher bar (thin silver metal bar with drilled holes)
- 6 x winder (rotating barrel for tensioning line wire)

For **2400mm (8ft)** high fencing:

- 2 x strut (thinner cylindrical post with drilled hole at the end)
- 5 x corner bracket (see figure 2 in “**Section 5: Fence Fittings**” below)
- 2 x stretcher bar (thin silver metal bar with drilled holes)
- 8 x winder (rotating barrel for tensioning line wire)

As with the end posts, in order to concrete your posts into the ground you will need to dig holes approximately 200mm x 200mm square in the appropriate positions along the fence lines (the holes need to be deep enough to bury the part of the post which will not be above ground).

PLEASE NOTE that a corner post is the exception to the rule that the spine should be at 90 degrees to the direction of the fence line. For a corner post the spine must be positioned on the outside of the fencing, half way between the direction of the two runs of fencing you are connecting (this will be easier to judge by placing a corner bracket onto the spine of the upright post. You will then see the required position for the corner bracket, as the bracket arms need to point in the direction of your two connecting runs).

How to attach your struts to the post

As explained above, the struts on your corner post will need to be concreted into the ground at the same time as the upright post. In order to attach the struts, you need to fix one of the corner brackets to the upright post by slotting it into the holes on the spine of the post. This bracket should be positioned in the top half of the post, approximately three quarters of the way up the post.

A strut should then be bolted to each arm of this bracket (they should be at an angle of approximately 40 degrees to the post). The bottom of the struts should be concreted into the ground.

Attaching the other fittings

As with the end posts, for **1800mm (6ft)** and **1200mm (4ft)** high fencing you will need three runs of line wire along the fence line.

Therefore, a corner bracket will be required towards the top, middle, and bottom of the end post. Attach the corner brackets to the upright post by slotting them into the holes on the spine of the post, and fitting the bolt through the bracket.

For **2400mm (8ft)** high fencing you will need four runs of line wire along the fence line.

Therefore, a corner bracket will be required at four evenly spaced intervals on the post (including one at the top and bottom of the post). Attach the corner brackets to the upright post by slotting them into the holes on the spine of the post.

For **900mm (3ft)** high fencing you will only require two runs of line wire. Therefore, you need to position a corner bracket at the top and bottom of the post, plus one bracket for the struts.

PLEASE ALSO NOTE: As with the end post, the corner brackets have two holes on each bracket arm. A winder should be bolted onto the outer hole of each bracket arm. The inner hole will be used to bolt on the stretcher bar when you come to attach the chain link to the posts (see section 4 below).

Therefore, when you position the brackets onto the post, you need to ensure that the brackets are spaced so that they line up with the holes drilled into the stretcher bar (the stretcher bar does not need to be bolted to the strut bracket).

C. Straining Posts

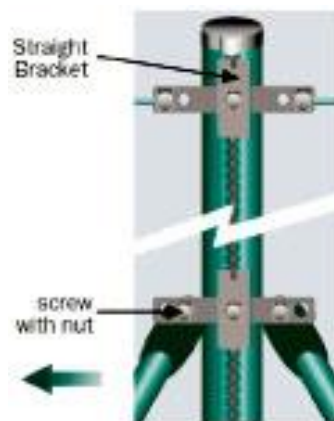

In addition to your upright post, a straining post contains the following fittings:

For **900mm (3ft)** high fencing:

- 2 x strut (thinner cylindrical post with drilled hole at the end)
- 3 x straining bracket (see figure 3 in “**Section 5: Fence Fittings**” below)
- 2 x stretcher bar (thin silver metal bar with drilled holes)
- 4 x winder (rotating barrel for tensioning line wire)

For **1200mm (4ft)** and **1800mm (6ft)** high fencing:

- 2 x strut (thinner cylindrical post with drilled hole at the end)
- 4 x straining bracket (see figure 3 in “**Section 5: Fence Fittings**” below)
- 2 x stretcher bar (thin silver metal bar with drilled holes)
- 6 x winder (rotating barrel for tensioning line wire)

For **2400mm (8ft)** high fencing:

- 2 x strut (thinner cylindrical post with drilled hole at the end)
- 5 x straining bracket (see figure 3 in “**Section 5: Fence Fittings**” below)
- 2 x stretcher bar (thin silver metal bar with drilled holes)
- 8 x winder (rotating barrel for tensioning line wire)

As with the end posts, in order to concrete your posts into the ground you will need to dig holes approximately 200mm x 200mm square in the appropriate positions along the fence lines (the holes need to be deep enough to bury the part of the post which will not be above ground).

How to attach your struts to the post

The struts on your straining post will need to be concreted into the ground at the same time as the upright post. In order to attach the struts, you need to fix one of the straining brackets to the upright post by slotting it into the holes on the spine of the post.

This bracket should be positioned in the top half of the post, approximately three quarters of the way up the post. A strut should then be bolted to each arm of this bracket (they should be at an angle of approximately 40 degrees to the post). The bottom of the struts should be concreted into the ground.

Attaching the other fittings

As with the end posts, for **1800mm (6ft)** and **1200mm (4ft)** high fencing you will need three runs of line wire along the fence line.

Therefore, a straining bracket will be required towards the top, middle, and bottom of the end post. Attach the straining brackets to the upright post by slotting them into the holes on the spine of the post, and fitting the bolt through the bracket.

For **2400mm (8ft)** high fencing you will need four runs of line wire along the fence line.

Therefore, a straining bracket will be required at four evenly spaced intervals on the post (including one at the top and bottom of the post). Attach the straining brackets to the upright post by slotting them into the holes on the spine of the post.

For **900mm (3ft)** high fencing you will only require two runs of line wire. Therefore, you need to position a straining bracket at the top and bottom of the post, plus one bracket for the struts.

PLEASE ALSO NOTE: As with the end post, the straining brackets have two holes on each bracket arm. A winder should be bolted onto the outer hole of each bracket arm. The inner hole will be used to bolt on the stretcher bar when you come to attach the chain link to the posts (see section 4 below). Therefore, when you position the brackets onto the post, you need to ensure that the brackets are spaced so that they line up with the holes drilled into the stretcher bar (the stretcher bar does not need to be bolted to the strut bracket).

D. Intermediate Posts



Intermediate posts (or upright posts) are the long cylindrical posts with a spine running down its length. They should be positioned every 3m along the fence (again, these posts should be concreted in).

No fittings are required for the intermediate posts, as the line wire is simply run past the spine side of the post and is secured to the post using the clip tool and hog rings (this is achieved by using the clip tool to fasten a hog ring over the line wire and through the holes on the spine of the post).

Please note that it is necessary to purchase a single clip tool in order to attach the line wire to the intermediate posts. You can use either the Professional Single Clip Tool or the FP20 Clip Tool (pictured below) to attach the line wire to the post spine.



Section 3: How to tension the line wire

Once you have concreted in your posts, and attached the necessary struts, brackets and winders, the next step is to tension your line wire. To achieve this you need to secure the end of the line wire to the cylinder on your winder (simply thread the line wire through the hole in the cylinder, and wrap it round a few times).

Once the line wire is secure, you should run it to the corresponding winder on the fence post at the far end of your run of fencing (this will either be another end post, a straining post, or a corner post). As explained above, the line wire should run past the spine side of the intermediate posts, and then be clipped onto the spine using the clip tool and hog rings.

Once the line wire is attached securely to two opposite posts, use a spanner on the winder bolt to rotate its cylinder. This will tension the line wire.

Section 4: How to attach the chain link to the line wire

Once each run of line wire has been tensioned along your run of fencing, the next step is to attach your chain link.

Step 1:

Hold the roll of chain link upright against your starting post. **PLEASE NOTE that the chain link must be unrolled carefully from an upright position. If it is unrolled along the ground then the chain link will snag.**

In order to attach the chain link to your starting post, weave the supplied stretcher bar in and out of each hole at the start of the roll of chain link (the stretcher bar is the flat silver metal bar with holes drilled into it, see figure 5 in section 5 below). You then need to bolt the stretcher bar to the inner hole of each of the brackets to which the line wire has been secured.

Step 2:

The chain link should now be rolled out along the runs of tensioned line wire (keeping the roll upright). As you unroll the chain link, use the magazine loaded FP222 hog ring pliers (or the Single Clip Tool) with the VR22 hog rings to attach the chain link to the line wire. You should space approximately three hog rings a metre along each run of wire.

To ensure a rigid fence, the chain link must be taut. This is achieved by **manually pulling the chain link tight** as you go along (as you pull the chain link tight, the hog rings will slide along the tensioned line wire).

What do I do when I reach the end of my run?

You will reach a stage where you need to stop your run of chain link (i.e. when you reach either another end post / straining post / corner post). However, you may find that the point at which you need to stop the run is part way along the roll of chain link.

If this is the case, then you can separate a section of chain link from the remainder of the roll. This is done by untwisting the wire on the diamond at the top and bottom of the chain link. Once these wires have been untwisted you will see that one of the strands of wire (the wire is a corkscrew shape) can be twisted so that it unravels from the fencing. Once you have removed the strand of wire, your run of fencing will be separated from the remainder of the roll. Therefore, it is not necessary to cut chain link fencing.

Once you have separated off the correct length of chain link from the roll, to complete your run of fencing you should weave another stretcher bar through each hole at the end of the chain link. This stretcher bar should then be secured to the brackets on your finishing post.

As we have highlighted throughout this guide, the key to a rigid fence is to ensure that the chain link is pulled tight. Therefore, we suggest that before you separate your section of chain link from the roll, you should work out the exact point you need to stop the run to ensure that the chain link will be sufficiently tight when secured to your finishing post.

PLEASE NOTE that when you reach a straining post or corner post, that is essentially the end of a straight run of fencing (so you should secure the chain link to the post's brackets using a stretcher bar). You will then need to start a new run of fencing using a stretcher bar attached to the other side of the post.

What do I do if I need to attach two rolls of chain link together?

If your run of fencing is longer than the roll supplied (i.e. you need to use more than one roll in a single run), then you can connect two runs of chain link together. This is achieved by using the same technique described above for separating sections of chain link (continued on next page).

The only difference is that when you are connecting two pieces of chain link, you need to unravel the corkscrew shaped strand of wire at the very end of the roll (ensuring that you do not bend the strand of wire out of shape). This strand of wire should then be used to weave together the two sections of chain link you need to connect (by twisting the strand of wire back in). Once you have done this, you need to twist shut the loose strands on the top and bottom diamond of the chain link to hold the strand in place.

Section 5: Fence Fittings

Figure 1: End Bracket

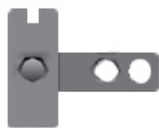

Figure 2: Corner Bracket



Figure 3: Straining Bracket



Figure 4: Winder



Figure 5: Stretcher Bar

